

WATER | WASTE - WATER TREATMENT

# Gramco



## RO 8 Series



**T:** 01 8612201

**F:** 01 8612203

**E:** [info@gramco.ie](mailto:info@gramco.ie)

**A:** Unit 5, Old Quarry Campus,  
Northwest Business Park,  
Phase 3, Blanchardstown,  
D15. Y4EK

# Reverse Osmosis - 8-Series

## The Basics

Reverse osmosis is a process that is used to remove a wide range of salts to give water of a high purity. Osmosis is a natural process involving fluid flow across a semi-permeable membrane barrier. It is the process by which nutrients feed the cells in our bodies and how water gets to leaves at the top of trees. If you separate a solution of salts from pure water using a basic thin semi-permeable membrane like a sausage skin, the pure water passes through the membrane and tries to dilute the salt solution. If the salt solution is connected to a vertical pipe then the progressively diluted solution will fill the pipe until the osmotic pressure drawing the pure water through the membrane is the same head pressure as the diluted solution.



This process can be reversed, hence 'reverse osmosis' - by applying a higher pressure to the salt solution. Pure water will then pass the other way through the membrane in a process that is easy to visualise as 'filtration' where the filter will only let through the small water molecules and retain almost all of the other molecules. This means that water containing a high level of natural salts can be purified without the need for chemical regenerants such as the acid and alkali used in demin plants.

Reverse osmosis is therefore considered a much safer route of producing pure water for many commercial and industrial applications, and additionally the plant doesn't need to be taken out of service for regeneration as a demin plant does.

Rejection rates of salts from water is generally in the region of 95-99.5% dependant upon the membrane type used and the raw water feed quality. RO systems can be designed to utilise the wide range of membranes available, which will give different permeate water qualities. Standard designed RO's are manufactured using the low energy membranes which will give a permeate water quality of approx 10 microsiemens from an input water of between 500-700 microsiemens.

Reverse osmosis systems, in their most basic form, consist of a pressure pump, housing and membrane. Water is forced into the housing under pressure and the pure water (or permeate) is collected and passed to service. Reject water (or concentrate) is collected from another outlet and routed to drain, with a portion of the concentrate water recycled back to the inlet of the pump. This means that the portion of water sent to drain is kept to a minimum, allowing a recovery ratio of approx 75% to be achieved without significant fouling of the membrane. The recirculation allows a higher flow of water through the pump, reducing the load on it's bearings and keeping the pump running cooler. The recirculation on all units is adjustable.

The controller used on the RO system constantly monitors the quality of the permeate water and is also linked with safety controls on the system, to ensure the unit cuts out on low & high pressure, high & low conductivity, and full permeate tank signal. It will also run various pre and post flush cycles to maximise the life of the membranes. The constant monitoring is automatic and the programming is all pre-set to ensure protection of the system at all times and to maximise the quality of the pure water.

## Pre-treatment

RO plants must be supplied with softened and de-chlorinated water. A duplex softener is recommended for continuous operation. Utilising softened water for the feed to the RO will reduce the scaling potential on the membrane and therefore lengthen it's working life. De-chlorination of the feed will reduce oxidation damage to the surface of the membrane. Membranes can also be fouled by Iron, Manganese, organics and micro-organisms. For boreholes and other private supplies a full water analysis is advised before installing an RO so that a pre-treatment system can be specified.

# Reverse Osmosis - 8-Series

## Technical Table

Model	ROPRO8-50	ROPRO8-75	ROPRO8-100	ROPRO8-8-150	ROPRO8-200	ROPRO8-300	ROPRO8-400
Output (m3/hr)	2.5	3.75	5.0	7.5	10.0	15.0	20.0
Input (lph)	3.33	5.0	6.66	10.0	13.33	20.0	26.67
Flush volume required for start up (lph)	4.2	6.25	8.25	12.50	16.67	25.0	33.34
Membrane type	OROM8040-1	OROM8040-1	OROM8040-1	OROM8040-1	OROM8040-1	OROM8040-1	OROM8040-1
Membrane number	2	3	4	6	8	12	15
Booster pump power (kw)	5.5	5.5	5.5	11.0	11.0	11.0	18.50
Amps	11.5	11.5	11.5	22.0	22	28	36
Power supply	Three phase	Three phase	Three phase	Three phase	Three phase	Three phase	Three phase
Inlet connection	2" S/U	2" S/U	2" S/U	2" S/U	2" S/U	2" S/U	3" Flange
Permeate connection	1.5" S/U	1.5" S/U	1.5" S/U	1.5" S/U	1.5" S/U	1.5" S/U	2" S/U
Drain	1.5" S/U	1.5" S/U	1.5" S/U	1.5" S/U	1.5" S/U	1.5" S/U	2" S/U
Suggested softener	120L duplex	200L duplex	250L duplex	300L duplex	500L duplex	750L duplex	1000L duplex
Delivered weight	300kg	400kg	450kg	600kg	600kg	900kg	1200kg
Included pre-treatment	Particulate	Particulate	Particulate	Particulate	Particulate	Particulate	Particulate
Width x depth x height (mm)	3000 x 1100 x 1750	4100 x 1100 x 1750	4100 x 1100 x 1750	4100 x 1100 x 1750	4900 x 1100 x 1711	4900 x 1100 x 1711	5900 x 1100 x 1711

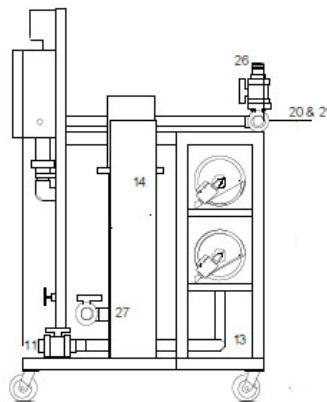
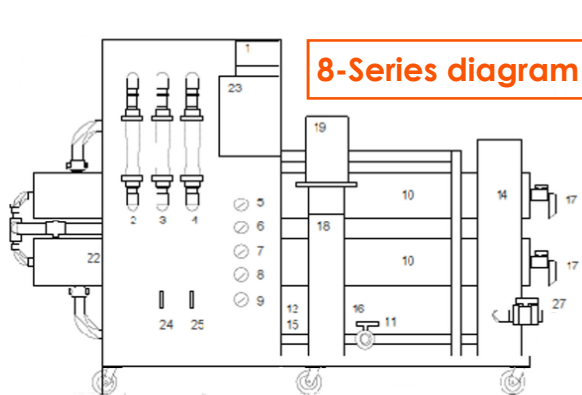

## Overview

The 8-series RO uses a large stainless steel skid and 8" membranes housed within stainless steel vessels to provide high flow rates. They come complete with a skid mounted particulate filter. A separate Carbon filter will be required if using mains water to provide Chlorine free water for the membranes. Due to the high flow rates of these systems it's important that the site is able to provide the volume and pressure required to meet the requirements of the flush phases listed on the table above.

8-series RO's can be built using shorter membrane housings stacked horizontally. This results on a smaller footprint which may be useful on sites with space limitations.

- |   |   |  |
|---|---|--|
| <ul style="list-style-type: none"> <li>1. Controller</li> <li>2. Permeate flow meter</li> <li>3. Concentrate flow meter</li> <li>4. Re-circ flow meter</li> <li>5. Raw inlet pressure gauge</li> <li>6. Filtered inlet pressure gauge</li> <li>7. Pump pressure gauge</li> <li>8. Inter-housing pressure gauge</li> <li>9. Back pressure gauge</li> </ul> | <ul style="list-style-type: none"> <li>10. Membrane housing</li> <li>11. Cleaning inlet port</li> <li>12. Flush solenoid</li> <li>13. Inlet solenoid</li> <li>14. Sediment filter housing</li> <li>15. High pressure switch</li> <li>16. Low pressure switch</li> <li>17. Permeate sample port</li> <li>18. Pump</li> </ul> | <ul style="list-style-type: none"> <li>19. Pump motor</li> <li>20. Permeate outlet</li> <li>21. Concentrate outlet</li> <li>22. Conductivity probe</li> <li>23. Pump control gear</li> <li>24. Pressure control valve</li> <li>25. Re-circ control valve</li> <li>26. Cleaning port outlet</li> <li>27. Raw water inlet</li> </ul> |
|---|---|--|

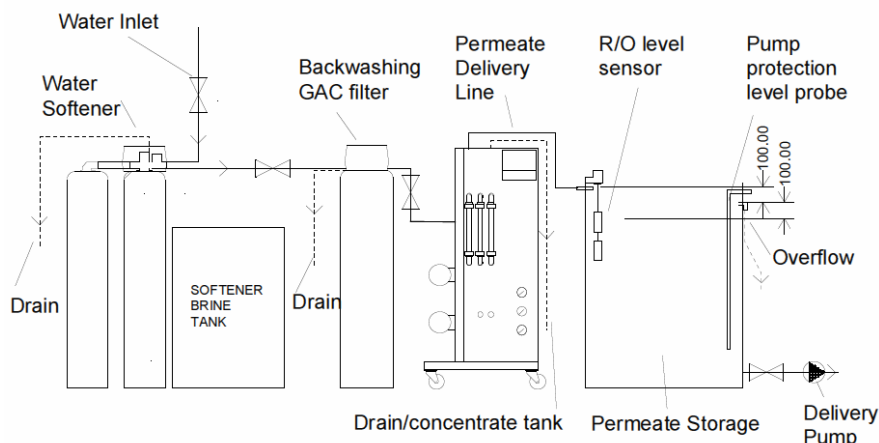

The diagram to the left shows a typical plumbing layout involving a reverse osmosis system. The softened water is fed to a backwashable Carbon filter before entering the 8-series RO. Water is then forced at high pressure through the membranes and the resulting permeate can then be collected in the permeate storage tank. Level probes (which are included in the RO system) control the operation of the RO. A delivery pump (suitable for use with RO water) may be used to boost the treated water to service.